

**Short Stroke Transducer  
potentiometric  
with integrated signal  
processing  
25 mm up to 150 mm**

Series TE1



**Special features**

- Extremely compact design 18 x 18 mm
- Long life up to 100 million movements
- Outstanding linearity up to  $\pm 0.075\%$
- Repeatability to  $\pm 0.002$  mm
- Models with push rod or spring-loaded with internal return spring
- Actuating shaft with double-sided support
- Compatible to standard probe tips
- Insensitive to shock and vibration
- Optionally cable or plug connection
- Special ball-coupling eliminates lateral forces
- High operational speeds - up to 10 m/s
- Integrated signal processing for normalized output signals current or voltage
- Low temperature coefficient < 20 ppm/K
- Series T/TS TR/TRS without integrated signal processing in same design see separate data sheet
- Inductive series LS1 in same design see separate data sheet

**Compact transducer with proven conductive-plastic technology and integrated signal processing.**

The model with push rod and ball coupling enables a backlash- and lateral force-free operation even with parallel and angular displacement of transducer and measuring direction. Characteristic for the robust design is the double-sided support of the actuating rod. For the spring-loaded type, this bearing allows high lateral forces on the tip of the rod which may occur during scanning of cams or wedge plates.

The linear transducer with integrated signal processing (4 ... 20 mA or 0 ... 10 V) is connected directly to the analog inputs of the controller.

**Applications**

- Measuring / control technology
- Manufacturing Engineering
  - Woodwork machines
  - Riveting machines
  - Packaging machines
  - Welding machines
- Assembly / Test devices
- Medical appliances
- Building technology

## Contents

<b>Mechanical data</b>	3
Dimension drawing	4
<b>Technical data</b>	5
Ordering code	5
<hr/>	
<b>Accessories</b>	
M8 connector system	6
Sensor mounting	7
Signal processing	7

## Mechanical Data

<b>Description</b>						
Housing	aluminum AlMgSi, anodized					
Mounting	adjustable clamps 2 x Z-45 and 4 x cylinder screw M4x10 (included in delivery)					
Actuating rod	stainless steel AISI 303, 1.4305 spring-loaded type: with anti-twist safeguard, internal thread M2.5x6					
Ball coupling for push rod type	hardened ball with spring pressure on carbide plate (included in delivery)					
Probe tip for spring-loaded type	stainless steel with external thread M2.5 and pressed-in hardened metal ball (included in delivery)					
Bearings	double-sided DU glide bearings					
Resistance element	conductive-plastic					
Wiper	precious metal multi-finger wiper, elastomer damped					
Electrical connections	3-pin connector M8x1, shielded 3-pole cable, PVC insulated, 0.14 mm <sup>2</sup> (AWG 26), shielded, 2 m length					
<b>Mechanical Data</b>						
Maximum permitted torque for mounting screws	140					Ncm
<b>Push rod type</b>	<b>TE1-0025-101</b>	<b>TE1-0050-101</b>	<b>TE1-0075-101</b>	<b>TE1-0100-101</b>	<b>TE1-0150-101</b>	
Housing (dimension A)	63	88	113	138	188	+1 mm
Mechanical stroke (dimension B)	30	55	80	105	155	±1.5 mm
Maximum operational speed	10					m/s
Weight						
with cable	183	202	222	245	328	g
with connector	138	157	177	201	280	g
Weight of shaft with coupling and wiper	35	43	52	58	74	g
Operating force (horizontally)	≤ 0.30					N
Max. displacements of ball coupling	±1 mm parallel offset, ±2.5° angular offset					
<b>Spring-loaded type</b>	<b>TE1-0025-102</b>	<b>TE1-0050-102</b>	<b>TE1-0075-102</b>	<b>TE1-0100-102</b>		
Housing (dimension A)	63	94.4	134.4	166		+1 mm
Mechanical stroke (dimension B)	30	55	80	105		±1.5 mm
Flange nut (dimension C)	12	12	12	12		mm
Excess length of push rod in end position (dimension D)	32	32	32	32		mm
Weight						
with cable	174	197	228	294		g
with connector	128	152	183	248		g
Weight of shaft with wiper	25	36	48	57		g
Operating force extended (horizontally)	≤ 2.5					N
Operating force retracted (horizontally)	≤ 5.0					N
Operating force to end stop	max. 5					N
Operating frequency (maximum) *	18	14	11	10		Hz
<b>Environmental Data</b>						
Temperature range TE1	-40 ... +85					°C
Operating humidity range	0 ... 95 (no condensation)					% R.H.
Vibration (IEC 60068-2-6)	5 ... 2000 Amax = 0.75 amax = 20					Hz mm g
Shock (IEC 60068-2-27)	50 11 (single hit)					g ms
Life	> 100x10 <sup>6</sup>					movem.
Protection class (DIN EN 60529)	IP40					

\*) Data refer to critical application "probe tip upwards"

## Dimension drawing

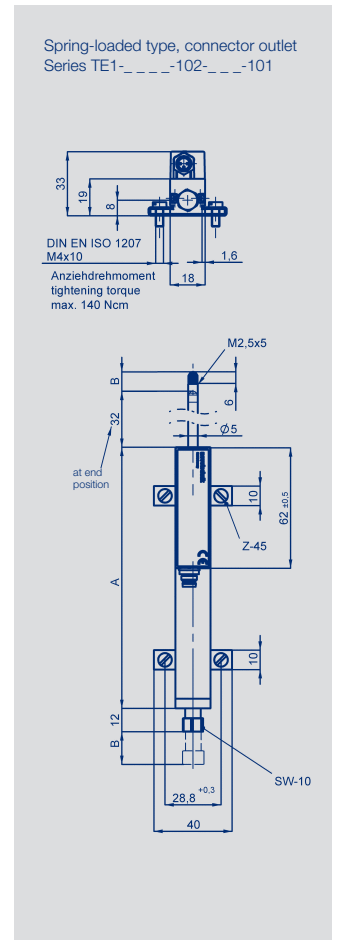
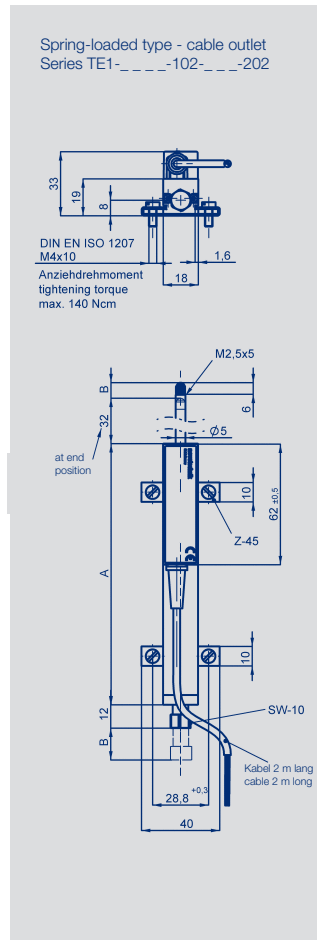
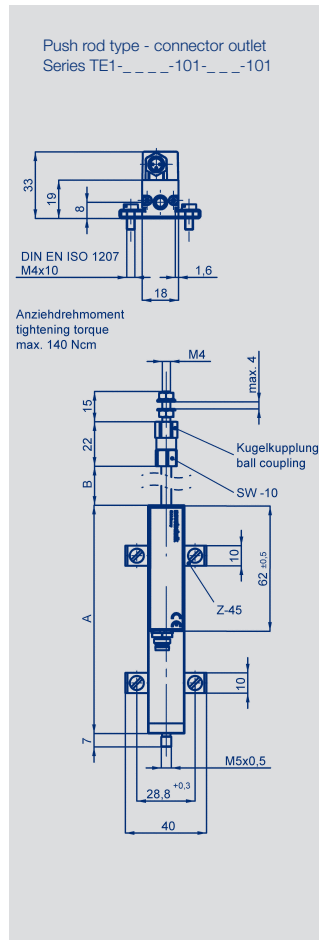
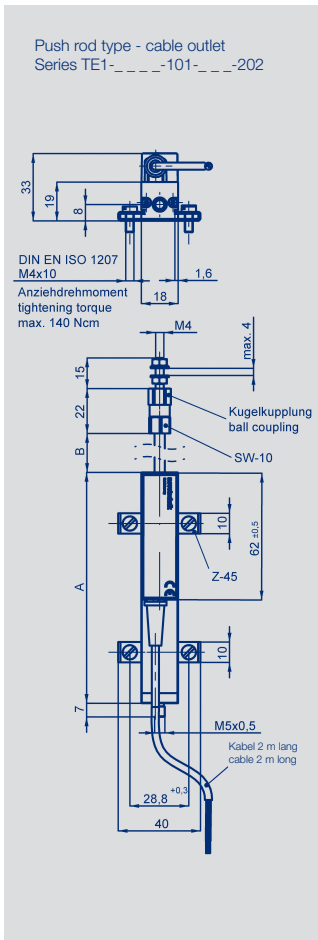

### Connection assignment

Signal	Cable code 202	Connector code 101	Connector with cable EEM 33-56 /-57 /-58 /-59 /-60 /-61
Supply voltage Ub	GN	pin 1	BN
Signal output	WH	pin 4	BK
GND	BN	pin 3	BU

### Rising characteristic output

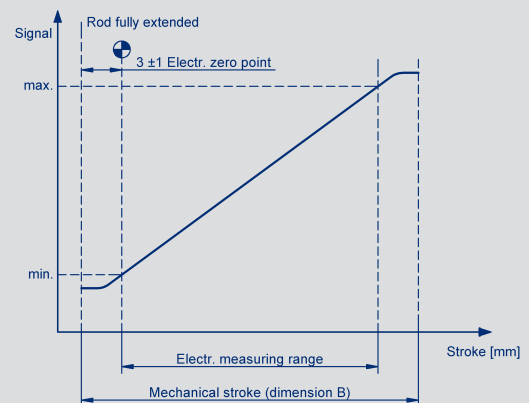

CAD data see  
[www.novotechnik.de/en/download/cad-data/](http://www.novotechnik.de/en/download/cad-data/)

## Technical Data Ordering Code

Type	TE1-0025	TE1-0050	TE1-0075	TE1-0100	TE1-0150	
<b>Electrical Data</b>						
Measuring range	25	50	75	100	150	mm
Independent linearity *	0.2	0.15	0.1	0.075	0.075	± % FS
Absolute linearity *	0.275	0.225	0.175	0.15	0.15	± % FS
Repeatability	0.002					±mm
Resolution	unlimited					
Dynamic (electrically)	> 10					kHz
Tolerance of electr. zero point	typ. ± 1.0					mm
Output signal voltage or current	0 ... 10 V (load ≥ 10 kΩ, residual voltage ≤ 10 mV) 10 ... 0 V (load ≥ 10 kΩ, residual voltage ≤ 10 mV) 4 ... 20 mA (burden ≤ 500 Ω) 20 ... 4 mA (burden ≤ 500 Ω)					
Short circuit protection	yes, all outputs vs.GND and Ub					
Supply voltage Ub	16 ... 30					V
Supply voltage ripple	max. 10					% Vss
Power consumption without load	< 1					W
Temperature coefficient	< 20					ppm/K
Overvoltage protection	< 36 (permanent)					V
Reverse protection	yes, supply lines					
Insulation resistance (500 VDC)	≥ 10					MΩ
<b>Environmental Data</b>						
MTTF (ISO 13849-1, parts count method, w/o load)	25					Jahre
Functional safety	If you need assistance in using our products in safety-related systems, please contact us					
EMC compatibility	EN 61000-4-2 Electrostatic discharge (ESD) 4 kV, 8 kV EN 61000-4-3 Electromagnetic fields 10 V/m EN 61000-4-4 Fast transients (Burst) 1 kV EN 61000-4-6 Conducted disturbances, induced by RF-fields 10 V eff. EN 61000-4-8 Power frequency magnetic fields 30 A/m EN 55016-2-3 Radiated disturbances class B					

\*) Other linearities on request

### Ordering specifications

Preferred types printed in bold

### Electrical interface

**4: Analog interface**

**Output signal analog interface 4 \_ \_**

**1: Voltage output**

**2: Current output**

**Analog interface voltage output 41 \_**

**1: 0 V ... 10 V (actuating rod extended = 0 V)**

**2: 10 V ... 0 V (actuating rod extended = 10 V)**

**Analog interface current output 42 \_**

**1: 4 mA ... 20 mA (actuating rod extended = 4 mA)**

**2: 20 mA ... 4 mA (actuating rod extended = 20 mA)**

**Electrical connection**

**101: Connector M8x1, 3-pin, axial output**

**202: Cable, 3-pole, 2 m, shielded**

**T E 1 - 0 1 0 0 - 1 0 2 - 4 1 1 - 1 0 1**

Series

Electrical measuring range  
Standard lengths  
0025 mm up to 0150 mm

Mechanical versions  
101: Push rod type  
102: Spring-loaded type (max. 100 mm)

**Accessories**  
Connector System M8

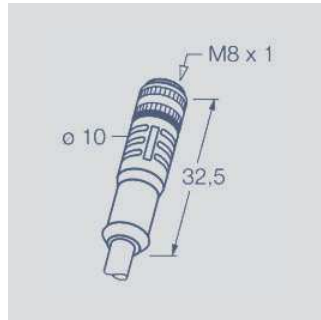

Pin assignment

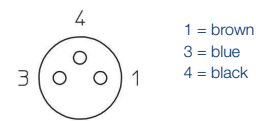

**M8x1 Mating female connector, 3-pin, straight, with molded cable, shielded, IP67, open ended**

Connector housing	Plastic PA	
Cable sheath	PUR; Ø = max. 6 mm, -40 °C ... +90 °C	
Wires	PP, 3x0.25 mm <sup>2</sup>	

Length	Type	P/N
2 m	EEM 33-56	005602
5 m	EEM 33-58	005604
10 m	EEM 33-60	005606

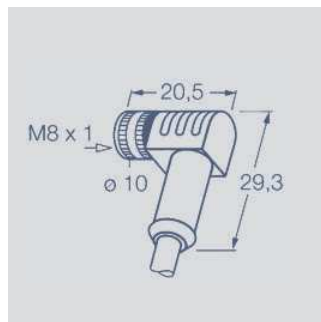

Pin assignment

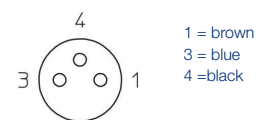

**M8x1 Mating female connector, 3-pin, angled, with molded cable, shielded, IP67, open ended**

Connector housing	Plastic PA	
Cable sheath	PUR; Ø = max. 6 mm, -40 °C ... +90 °C	
Wires	PP, 3x0.25 mm <sup>2</sup>	

Length	Type	P/N
2 m	EEM 33-57	005603
5 m	EEM 33-59	005605
10 m	EEM 33-61	005607

**IP67** Protection class IP67 (DIN EN60529)

Very good resistance to oils, coolants and lubricants

Very good Electromagnetic Compatibility (EMC) and shielded systems

Suited for applications in dragchains

**Note:** The protection class is valid only in locked position with its plugs. The application of these products in harsh environments must be checked in particular cases.

**Accessories**  
Sensor mounting  
Signal processing

Novotechnik  
Messwertaufnehmer OHG  
Postfach 4220  
73745 Ostfildern (Ruit)  
Horbstraße 12  
73760 Ostfildern (Ruit)  
Telefon +49 711 4489-0  
Telefax +49 711 4489-118  
info@novotechnik.de  
www.novotechnik.de



© 02/2017  
Printed in Germany

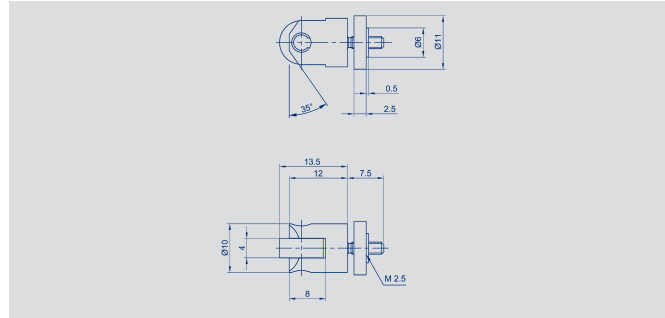

**Roller head**, hardened steel.  
Mounting via external thread M2.5 at push rod. Lock with knurled screw.

Type Z-R50, P/N 005678

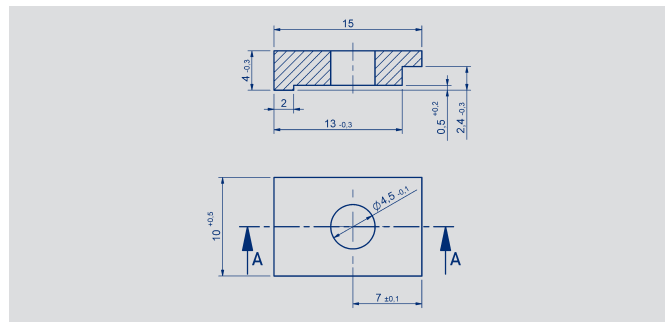
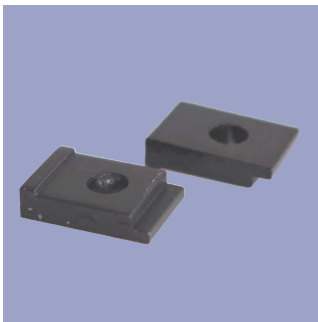

**Clamps**  
4 single clamps, anodized aluminum, with screw M4x10 - 4.8 tinned, for lower total height  
Type Z-FTI-B01, P/N 059010

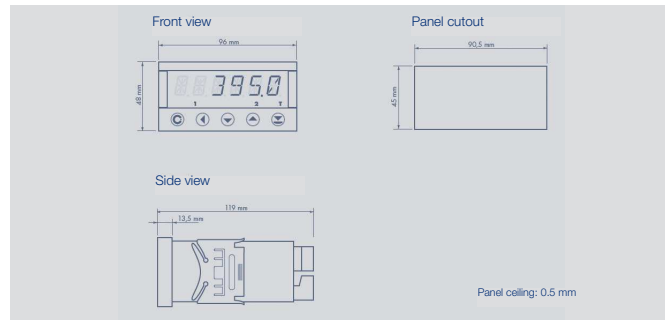

**Multifunction Display**  
Microprocessor-controlled measuring devices for direct connection of potentiometric sensors or sensors with standardized analog output signals.  
• accuracy up to 0.1 %  
• display range -99 999...999 999  
• good cost/value ratio

Type MAP-40 \_ \_ \_ \_ \_

Detailed data see separate  
Data sheet MAP-4000

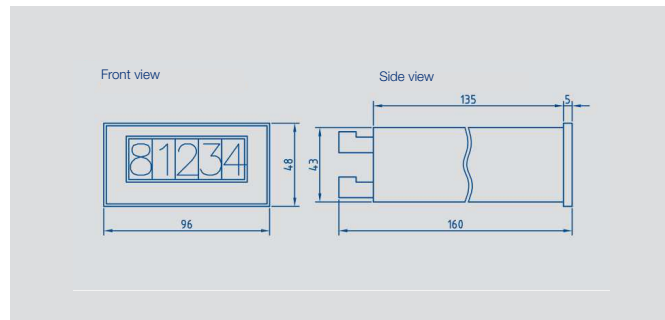

**Multifunction displays**  
Microprocessor-controlled measuring devices with galvanic isolation for direct connection of potentiometric sensors or sensors with standardized analog output signals.  
• accuracy up to 0.01 %  
• display range -9 999...40 000

Type MAP-3(4) \_ \_ \_ \_ \_

Detailed data see separate  
Data sheet MAP-300/400

The specifications contained in our datasheets are intended solely for informational purposes. The documented specification values are based on ideal operational and environmental conditions and can vary significantly depending on the actual customer application. Using our products at or close to one or more of the specified performance ranges can lead to limitations regarding other performance parameters. It is therefore necessary that the end user verifies relevant performance parameters in the intended application. We reserve the right to change product specifications without notice.